

SONICATOR[®]



Ultrasonic Liquid Processors

QSONICA *manufacturers of*
MISONIX SONICATORS

Index

How Does a Sonicator Work	2-3
Direct vs. Indirect Sonication.....	3

Q700 Sonicator	4-5
-----------------------------	------------

Q500 Sonicator	6
-----------------------------	----------

Accessories for the Q700 and Q500	7-15
Direct Horn Options.....	7-9
Standard Probes	7
Replacement Tips and Microtips	8
Extenders, Boosters, and High Gain Horns	9
High Throughput Horns	10
<i>96 Tip Horn, Dual Horn, 4 Tip Horn</i>	
Flocells.....	11
Indirect Horn Options.....	12-13
<i>Cup Horns and Microplate Horns</i>	
General Accessories	14-15
<i>Enclosures, Stands, etc.</i>	

Q125 Sonicator	16
Q125 Accessories	17

Q55 Sonicator	18
----------------------------	-----------

Q1375 Sonicator	19
------------------------------	-----------

QA40 Atomizer	20
----------------------------	-----------

How Does a Sonicator Work?



Generator → **Converter** → **Probe/Horn**

A Sonicator system is comprised of 3 major components: Generator, Converter and Horn (also known as a probe).

The ultrasonic electronic **Generator** transforms AC line power to high frequency electrical energy. The generator features a keypad or buttons which allow the user to control the sonication parameters.

The generator provides high voltage pulses of energy at a frequency of 20 kHz that drives a piezoelectric **Converter**. The converter is a cylindrical device which is connected to the generator by a high voltage cable. The converter transforms electrical energy to mechanical vibration due to the characteristics of the internal piezoelectric crystals.

The vibration is amplified and transmitted down the length of the **Probe/Horn**. Probes have threaded ends and attach to the converter. During operation, the probe's tip longitudinally expands and contracts. Amplitude is the distance the tip travels and is dependent on the amplitude setting selected by the user.

In liquid, the rapid vibration of the tip causes cavitation, the formation and violent collapse of microscopic bubbles. The collapse of thousands of cavitation bubbles releases tremendous energy in the cavitation field. Objects and surfaces within the cavitation field are "processed." By increasing the amplitude setting, cavitation intensity within the sample is also increased.

The probe tip diameter dictates the amount of sample that can be effectively processed. Smaller tip diameters deliver high intensity sonication but the energy is focused within a small, concentrated area. Larger tip diameters can process larger volumes, but offer lower intensity. Boosters can be used to increase the intensity of a larger tip probe to speed up processing times.

To ensure a positive outcome, it is important to select the appropriate generator and probe to match the volume, viscosity and other parameters of each particular application. Please consult with a Sonicator product specialist for help making the optimum choices.

Direct vs. Indirect Sonication Methods

DIRECT Sonication (inserting a probe directly into a sample vessel) is the most common way to process a sample. Energy is transmitted from the probe directly into the sample with high intensity and the sample is processed quickly.

The diameter of the probe's tip dictates the liquid volume that can be effectively processed. Smaller tip diameters (Microtip probes) deliver high intensity sonication and the energy is focused within a small, concentrated area. Larger tip diameters can process larger volumes, but offer lower intensity. Boosters and High Gain horns can be used to increase the output of large diameter probes. Probes are offered with either replaceable or solid tips and are made from titanium.



INDIRECT Sonication eliminates the need for a probe to come in contact with your sample. This technique is often described as a high intensity ultrasonic bath. The ultrasonic energy is transmitted from the horn, up through the water and into a vessel or multiple sample tubes.

Indirect sonication is most effective for very small samples because foaming and sample loss are eliminated. Pathogenic or sterile samples are ideal for this method because aerosols and cross contamination are prevented. The Cup Horn and Microplate Horn deliver indirect sonication and are ideal for many high throughput applications.



Q700 Sonicator

The new Q700 is the most technologically advanced sonicator available today. A state-of-the-art touch screen interface offers intuitive control and provides a user-friendly experience. The most important feature of a Sonicator is reproducibility. Improved internal circuitry guarantees more efficient operation, sample-to-sample consistency and most importantly, a reliable end result.

The Q700 is the only sonicator on the market that offers full amplitude control from 1-100%. This enables greater control of the probe's intensity, helping to pinpoint the optimum settings for efficient sample processing. We have increased maximum power output to 700 watts making the system more durable and capable of handling even larger samples if necessary. Our new display, design improvements and added accessories make this the most sophisticated and versatile Sonicator available today.



Stand sold separately.

FEATURES:

FULL AMPLITUDE CONTROL

Amplitude (intensity) is controlled from 1-100% giving a greater degree of resolution and the ability to pinpoint the amplitude needed to effectively process your sample.

PROGRAMMABILITY

Parameters including processing times, pulse on/off and amplitude can be saved to memory and run by the touch of a button.

PULSE MODE

Adjustable pulse On and Off times to reduce the heat gain in temperature sensitive samples.

TEMPERATURE MONITORING

An optional temperature probe is available for those customers who wish to monitor the temperature of their sample. If the temperature limit is reached, sonication shuts down to prevent overheating

RoHS COMPLIANT

All Qsonica equipment is built lead free.

RUN MULTIPLE PROGRAMS IN SEQUENCE

Multiple programs can be run in sequence. For example, the unit can be programmed to sonicate at 50% amplitude for 5 minutes, shut off for 2 minutes and re-start at 25% amplitude for 10 minutes. Up to 5 programs can be run in succession.

TOTAL ENERGY OUTPUT DISPLAY

Energy delivered to the probe is displayed in both Watts and Joules.

AUTO TUNING

The Sonicator digitally tracks frequency changes in the converter / tip assembly caused by load and temperature changes and maintains electrical efficiency at all times. Manual tuning is unnecessary.

OVERLOAD PROTECTION

The unit is equipped with fault detection circuitry to shut down sonication in the event that a fault occurs.

TOUCH SCREEN CONTROL

A large, color LCD screen clearly displays all operating parameters and options. Intuitively and quickly access any of the sonicator's functions with a simple touch.



PART NO. Q700 INCLUDES:

- Generator
- Converter
- 1/2" diameter probe
- Power cable
- Converter cable
- Wrench set

TECHNICAL SPECIFICATIONS:

Power Rating:	700 watts
Frequency:	20 kHz
Programmability:	10 memories plus sequencing
Programmable Timer:	72 hours
Adjustable Pulse On/Off:	1 second to 24 hours
Dimensions:	8" W x 15.25" L x 8.5" H
Voltage:	110V, 50/60 Hz

Specify desired voltage for export.

Q500 Sonicator

The Q500 is a powerful ultrasonic processor featuring programmable operation and a digital display of operating parameters. Popular applications include nanoparticle dispersion, creating emulsions, cell lysis and homogenization.

Adjustable pulse On and Off times can be programmed from 1 second to 1 minute. Total programming has a maximum setting of 10 hours. A wide variety of probes and accessories are available to handle virtually any application.



Stand sold separately.

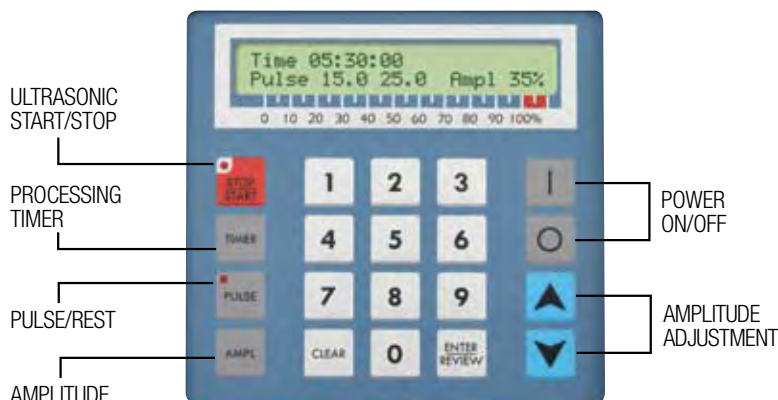

FEATURES:

Programmable operation

Set time and amplitude for hands free operation

Pulse mode

Prevent heat buildup in temperature sensitive samples

Digital amplitude / intensity control

Output intensity can be set from 20-100%

Elapsed time indicator

Displays duration of sonication

Display of wattage and joules

Real-time energy monitoring

Overload protection

Prevents damage to circuitry if a fault occurs

RoHS compliant

Uses lead free components

PART NO. Q500 INCLUDES:

- Generator
- Converter
- 1/2" diameter probe
- Power cable
- Converter cable
- Wrench set

TECHNICAL SPECIFICATIONS:

Power Rating:	500 watts
Frequency:	20 kHz
Programmable Timer:	10 hours
Adjustable Pulse On/Off:	1 second to 1 minute
Dimensions:	8" W x 15.25" L x 8.5" H
Voltage:	110V, 50/60Hz

Specify desired voltage for export.

Horns (also known as probes) are made from titanium and machined to specific sizes and shapes. When driven at their resonant frequency, they expand and contract longitudinally. This mechanical vibration is amplified and transmitted down the length of the probe. In liquid, the probe causes cavitation which constitutes the main mechanism for sample processing.

Choosing the appropriate horn is extremely important. The sample volume to be processed is directly related to the tip diameter. Smaller tip diameters (Microtip probes) deliver high intensity sonication, but the energy is focused within a small, concentrated area. Larger tip diameters can process larger volumes, but offer lower intensity. Probes are offered with replaceable, solid or sapphire tips.



Probe tips will pit or erode over time and require replacement. Using an excessively worn tip can affect your results and possibly overload the generator. Solid probes must be used for samples containing organic solvents or low surface tension liquids. Sapphire tips erode more slowly than titanium and are recommended for processing solutions that include abrasive materials.

Standard Probes



Part #	Type of Tip	Processing Volume	Tip Diameter	Intensity	Amplitude (microns)
4220	Replaceable Tip	10-250 ml	1/2" (12.7 mm)	High	120 µm
4219	Solid Tip	10-250 ml	1/2" (12.7 mm)	High	120 µm
4219S	Sapphire Tip	10-250 ml	1/2" (12.7 mm)	High	120 µm
4207	Replaceable Tip	25-500 ml	3/4" (19.1 mm)	Medium	60 µm
4208	Solid Tip	25-500 ml	3/4" (19.1 mm)	Medium	60 µm
4208S	Sapphire Tip	25-500 ml	3/4" (19.1 mm)	Medium	60 µm
4210	Replaceable Tip	50-1,000 ml	1" (25.4 mm)	Low	30 µm
4209	Solid Tip	50-1,000 ml	1" (25.4 mm)	Low	30 µm
4209S	Sapphire Tip	50-1,000 ml	1" (25.4 mm)	Low	30 µm

Replacement Tips for Standard Probes

Standard 1/2", 3/4" and 1" horns have replaceable tips. During normal use, tips erode and become less effective over time. These worn tips can be easily removed and replaced.



New Tip



Worn Tip

Part #	Tip Diameter	For Use With
4406	1/2" (12.7 mm)	#4220
4407	3/4" (19.1 mm)	#4207
4408	1" (25.4 mm)	#4210

Microtip Probes

Microtips are thin, high intensity probes which are designed for processing small sample volumes. Microtips screw into the threaded end of the standard 1/2" probe (#4220).

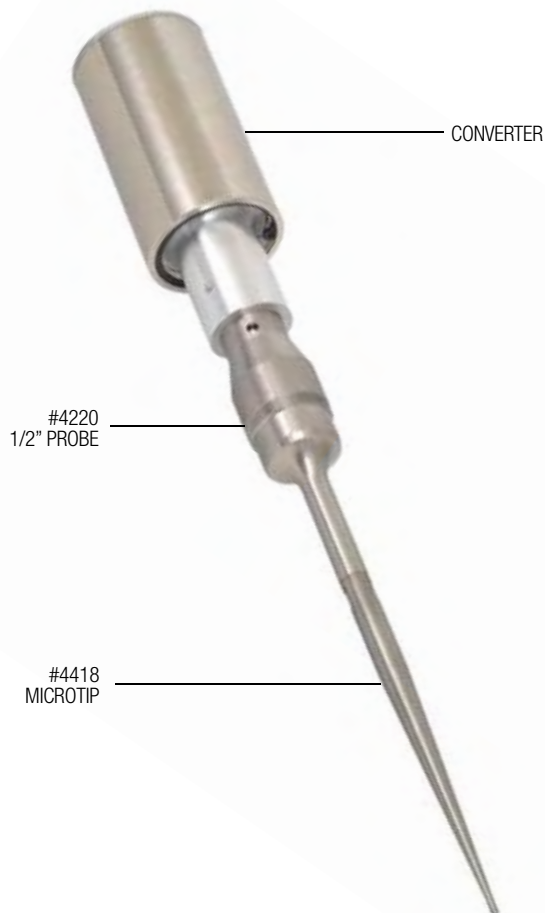

Part #	Processing Volume	Tip Diameter	Intensity	Amplitude (microns)
4417	0.2-5 ml	1/16" (1.6 mm)	Ultra High	320 µm
4418	0.5-15 ml	1/8" (3.2 mm)	Ultra High	240 µm
4420	5-50 ml	1/4" (6.4 mm)	High	170 µm
4422*	0.5-15 ml	1/8" (3.2 mm)	Very High	205 µm
4421*	Coupler required for use of a Stepped Microtip			



* Stepped Microtip Assembly
The coupler screws directly into the converter.



Extenders

Standard probes may not be long enough to fit down into certain long necked vessels. Extender probes attach to standard horns of the same tip diameter and extend the length of the horn assembly. Extenders are available in 5" and 10" lengths with either solid, or replaceable tips.



Part #	Type of Tip	Length	Tip Diameter
406HW	Solid Tip	5"	1/2" (12.7 mm)
406HWT	Replaceable Tip	5"	1/2" (12.7 mm)
407HW	Solid Tip	5"	3/4" (19.1 mm)
407HWT	Replaceable Tip	5"	3/4" (19.1 mm)
408HW	Solid Tip	5"	1" (25.4 mm)
408HWT	Replaceable Tip	5"	1" (25.4 mm)
406FW	Solid Tip	10"	1/2" (12.7 mm)
406FWT	Replaceable Tip	10"	1/2" (12.7 mm)
407FW	Solid Tip	10"	3/4" (19.1 mm)
407FWT	Replaceable Tip	10"	3/4" (19.1 mm)
408FW	Solid Tip	10"	1" (25.4 mm)
408FWT	Replaceable Tip	10"	1" (25.4 mm)

Extenders offer the same processing volume and amplitude of their corresponding standard horn.

Boosters



Booster horns increase the intensity of standard 3/4" and 1" horns. Boosters attach between the converter and horn to increase amplitude by the gain ratio indicated below. A 3 to 1 gain booster is available for custom applications.

Part #	For Use With	Gain Ratio
4121	3/4" and 1" Probes	2 to 1

High Gain Horns

High gain horns (also known as high intensity horns) offer double the amplitude of standard 3/4" and 1" horns. High gain horns attach directly to the converter.



Part #	Type of Tip	Processing Volume	Tip Diameter	Amplitude (microns)
4305	Replaceable Tip	25-500 ml	3/4" (19.1 mm)	120 µm
4306	Solid Tip	25-500 ml	3/4" (19.1 mm)	120 µm
4310	Solid Tip	50-1,000 ml	1" (25.4 mm)	60 µm
4311	Replaceable Tip	50-1,000 ml	1" (25.4 mm)	60 µm

96 Tip Horn

(only for use with Q700)



Process each well of a 96 well plate simultaneously with the 96 Tip Horn. Dissolution of solids, mixing and other low intensity applications are ideal for this horn. Each tip is .69" long and can be used with both standard and deep well microplates. When using deep well microplates, sample volume must be at least 1.5 ml.



Part #438 is a vertically adjustable stand (see page 15) that keeps the horn level and allows adjustment of the horn in and out of the microplate. The 432B sound enclosure (see page 14) is recommended for use with the horn and stand, to reduce the high noise level generated by sonication.

Part #	Description
4611	96 Tip Horn
438	Adjustable Stand
4599	Replacement Tips

4 Tip Horn

(only for use with Q700)



The 4 Tip Horn enables 4 samples to be processed simultaneously. Tip diameter is 1/8" and the space between each tip is 0.72".

Part #	Description
4559	4 Tip Horn
4598	Replacement Tips

Dual Horn



The Dual Horn allows a single Sonicator unit to process two samples simultaneously. The rectangular-shaped horn doubles the unit's output, and enables two probes to vibrate with the same intensity as a single probe. The distance from center to center of each probe is 4.5". 3/4" solid tip probes are included with the Dual Horn but 1/2" or 1" probes may also be used.

The Dual Horn is capable of withstanding the rigors and harsh chemicals of environmental testing labs. Sonication is used by environmental labs to process soil and sediment samples in lieu of soxhlet extraction methods. The Sonicator and Dual Horn meet the EPA requirements specified in method SW846-3550.

Dual Horn components can be ordered separately. The Dual Horn can be mounted in the Sound Enclosure (#432B) or on the Adjustable Stand (#438).

Part #	Description
4525	Dual Horn with Probes
4562	Rectangular Coupler Only
4208	Replacement 3/4" Solid Probe

Flocells offer inline or continuous, large volume, batch sample processing. Flocells are ideal for mixing and dispersing applications. Batch volumes can be recirculated through the system multiple times if increased sonication time is needed. Multiple units can be used in succession to reduce processing time and/or maintain an even higher flow rate.

The liquid sample is pumped into the Flocell through the inlet at the bottom of the unit. As the sample passes through the cavitation field, it is processed. The processed liquid exits the unit through an outlet port. The sample can be recirculated multiple times if necessary. The degree of processing can be controlled by adjusting the intensity of sonication as well as flow rate.

Low Volume Continuous Flocell



Part # 4495

SPECIFICATIONS:

- Dimensions: 9" H x 2" Diameter
- Material: 316L stainless steel
- Operating pressure: up to 40 psi
- Internal volume (with probe in place): 65 ml
- Maximum flow rate: 0.5 liters / min.
- ¼" NPT fittings
- Uses standard ½" diameter probe (probe sold separately)

High Volume Continuous Flocell

(only for use with Q700 or Q1375)

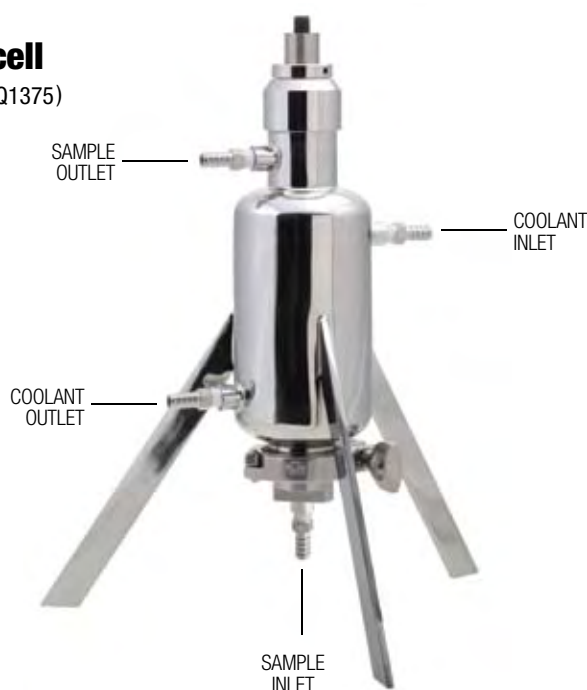

Part # 4583

SPECIFICATIONS:

- Dimensions: 17" H x 16" W
- Includes 1" diameter extender probe
- Material: 316L stainless steel
- Operating pressure: up to 100 psi
- Sanitary connections
- CIP/SIP ready
- Water jacketed for cooling
- Internal volume (with probe in place): 400 ml
- Maximum flow rate: 20 liters / min.

Cup Horn

Cup horns offer indirect sonication and function as high intensity ultrasonic water baths. Multiple samples can be processed in sealed tubes or vials eliminating aerosols and cross contamination. Cup Horn are ideal for sterile or pathogenic sample processing and enable multiple tubes to be processed at one time.

The horn is mounted within an acrylic cup and the cup is filled with water. Sample tubes are placed in a rack just above the horn. Cavitation is produced in the water, processing the samples within the tubes or vials. Coolant ports are on each side of the cup for circulation of cold water to keep samples from overheating. A microtube rack is included with each Cup Horn.

The Sound Enclosure (#432B) is highly recommended for all Cup Horn users. In addition to reducing sonication noise to safe levels, it securely supports the Cup Horn in the proper position. The Sound Enclosure features ports on either side to allow coolant tubing to pass from the Cup Horn to a water source or pump system outside the box.



Part # 431B1

Inner Diameter of Cup: 3"

Diameter of Horn: 2.5"

Tube Capacity: 8

Replacement Microtube Rack:
Part # 442



Part # 431C1

Inner Diameter of Cup: 5.5"

Diameter of Horn: 2.5"

Tube Capacity: 20

Replacement Microtube Rack:
Part # 443

(only for use with Q700)

Microplate Horn

(Only for use with Q700)

Similar to a Cup Horn, but larger, the Microplate Horn is an indirect sonication device capable of processing an entire 96 well microtiter plate or many microtubes at one time.

Simply place your samples within the water-filled reservoir and the sonic energy is transferred into each individual well or tube. This unit is ideal for high throughput applications.

The Horn is equipped with a clear acrylic collar to contain the liquid media within the reservoir. This allows the user to process deep well microplates or other tall vessels. Standard microtiter plates or PCR tubes require a smaller volume of liquid for sonication. For these applications, the clear acrylic collar may be removed and the lower, gray collar will allow for easier access to the samples.



#Q700MPX



#431MPX



#431MPXH

Part #	Description
Q700MPX	Q700 (Without Standard Probe), and the 431MPX
431MPX	Microplate Horn, Pinch Clamps, Tubing and Sound Enclosure
431MPXH	Microplate Horn Only
432MP	Sound Enclosure for Microplate Horn
444	300 µl Microcentrifuge Tube Holder/Cover

Exterior dimensions of the Sound Enclosure are 10" wide x 10" deep x 17" high.



#444

The Microplate Horn is commonly used in PMCA research. A microcentrifuge tube holder and cover (#444) are available and often used for this application.



432B shown with probe and jack stand
(Probe and jack stand sold separately.)



432B shown with cup horn
(Cup horn sold separately.)

Sound Enclosure

Sonication produces high pitch noise that can cause discomfort to the user and anyone nearby. The Sound Enclosure reduces noise by approximately 20 dBa and is made to work with all accessories (excluding the Microplate Horn which has its own dedicated enclosure).

The Sound Enclosure safely and securely holds the converter and probe assembly, an additional stand or clamp is not required. The Sound Enclosure also includes a removable collar and legs. By inverting the converter collar and attaching the legs the sound enclosure can be turned upside down for use with the Cup Horn.

There is a port on either side of the enclosure to allow tubing into the enclosure if necessary. A ½" diameter steel support rod is built into the enclosure allowing a clamp to hold a sample under the probe.

The interior is water resistant for easy cleaning and the door is clear for observation of experiments. Exterior dimensions are 14.5" wide x 23" high x 12" deep.

Part #	Description
432B	Sound Enclosure

Jack Stand



Raises and lowers sample vessels to a stationary probe mounted within the enclosure

Part #	Description
357	Jack Stand

Replacement Converter



Part #	Description
CL33	Replacement Converter

Replacement Microtube Racks

(Q700 only)



Part #	Description
442	8 Tube Capacity
443	20 Tube Capacity

Temperature Monitoring Options

(Q700 only)

Part #	Description
4103	Flexible Thermocouple

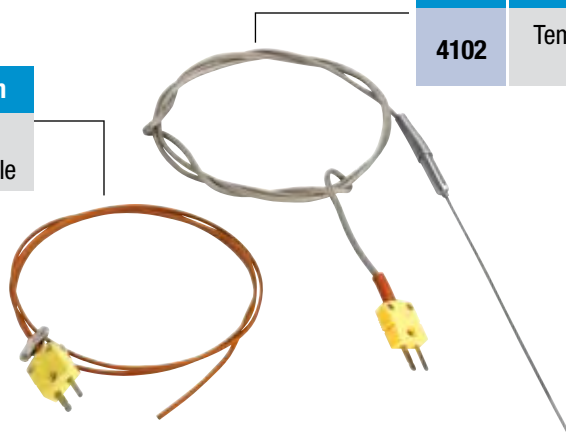

Part #	Description
4102	Temperature Probe

2 types of temperature probes are available for use with the Q700 Sonicator

Replacement Converter Cable



Part #	Description
K4	6 ft. Long
K4-10	10 ft. Long

Footswitch



Enables hands free operation

Part #	Description
FS-3	For Use with Q700
4004	For Use with Q500

Heavy Duty Stand

Part #	Description
438	Heavy Duty Stand

Converter & horn not included

Precisely raises and lowers the converter and probe/horn into a sample vessel



Large Clamp Stand

Part #	Description
459	Stand with 1/2" Diameter Support Rod and Converter Clamp



Q125 Sonicator

The Q125 is a microprocessor based, programmable ultrasonic processor. Features include pulse mode and a digital display of both wattage and joules.

The unit is effective for standard cell disruption, DNA/RNA shearing, homogenization and many other applications. The Q125 is ideal for small samples and for customers that do not plan to scale up to larger volumes in the future. This model offers the same programming and display features as the Q500 unit.



Stand sold separately.

FEATURES:

Programmable operation

Set time and amplitude for hands free operation

Pulse mode

Prevent heat buildup in temperature sensitive samples

Digital amplitude / intensity control

Output intensity can be set from 20-100%

Elapsed time indicator

Displays duration of sonication

Display of wattage and joules

Real-time energy monitoring

Overload protection

Prevents damage to circuitry if a fault occurs

RoHS compliant

Uses lead free components

Compact design

Takes up less space than competitive units



PART NO. Q125 INCLUDES:

- Generator
- Converter
- 1/8" diameter probe
- Power cable
- Converter cable
- Wrench set

TECHNICAL SPECIFICATIONS:

Power Rating:	125 watts
Frequency:	20 kHz
Programmable Timer:	10 hours
Adjustable Pulse On/Off:	1 second to 1 minute
Dimensions:	8" W x 13.75" L x 5.75" H
Voltage:	110V, 50/60 Hz

Specify desired voltage for export.

Probes



Probes	Part # 4423	Part # 4422	Part #4435
Processing Volume*	200 µl - 5 ml	500 µl - 15 ml	10 ml - 50 ml
Tip Diameter	5/64" (2 mm)	1/8" (3.2 mm)	1/4" (6.4 mm)
Amplitude (µm) Intensity Level	200 (very high)	180 (high)	120 (medium)

Cup Horn



Part # 4608
 Horn Diameter 25/32" (20 mm)
 Cup ID* 1.5" (38 mm)

**Accommodates (two) 1.5 ml microtubes or (one) 15 ml Falcon tube.*

8 Tip Horn



Part # 4602
 Tip Diameter 1/8" (3.2 mm)

Optional Accessories



#CL18



#460



#432A

Part #	Description
460	Support Stand with Converter Holder
432A	Sound Enclosure with Converter Holder (20" x 12" x 12")
CL18	Replacement Converter

Q55 Sonicator

The Q55 is a compact and cost effective ultrasonic processor that will occupy less bench space than any unit on the market.

This model is effective for standard cell disruption and many other small volume applications. Probes are available in three different sizes.

FEATURES:

- Smallest unit available
- Thumb-switch or continuous operation
- Simple and effective operation



Stand sold separately.



POWER ON/OFF

AMPLITUDE CONTROL

CONTINUOUS PROCESSING OR THUMB-SWITCH ACTIVATED PROCESSING



Probes	Part # 4423	Part # 4422	Part # 4435
Processing Volume*	200 μ l - 5 ml	500 μ l - 15 ml	10 ml - 50 ml
Tip Diameter	5/64" (2 mm)	1/8" (3.2 mm)	1/4" (6.4 mm)
Amplitude (μ m) Intensity Level	200 (very high)	180 (high)	120 (medium)

PART NO. Q55 INCLUDES:

- Generator
- Converter
- 1/8" dia. probe
- Power cable
- Converter cable
- Wrench set

TECHNICAL SPECIFICATIONS:

Power Rating:	55 watts
Frequency:	20 kHz
Dimensions:	8" W x 7.5" L x 5.75" H
Voltage:	110V, 50/60 Hz

Specify desired voltage for export.

Optional Accessories

Part #	Description
460	Support Stand with Converter Holder
432A	Sound Enclosure with Converter Holder (20" x 12" x 12")
CL118	Replacement Converter



#CL118



#460



#432A

Q1375 Sonicator

The Q1375 offers the ability to process industrial scale sample volumes in individual batches or flow through applications. This model includes a 1" diameter, 10" long probe and booster. The booster increases the amplitude of the probe which enables larger volumes to be processed.

The Q1375 Sonicator offers the ability to program processing times and a full range of intensity settings. Processing time can be set from 1 second to 10 hours. A pulsing feature is also included. Pulsing can reduce the amount of heat generated by sonication when processing temperature sensitive samples.

FEATURES:

- High volume capability
- Programmable operation
- Process up to 20 liters*

TECHNICAL SPECIFICATIONS:

Power Rating:	1,375 watts
Frequency:	20 kHz
Dimensions:	11" H x 15" W x 18.25" D
Voltage:	220V, 50/60 Hz



PART NO. Q1375 INCLUDES:

- Generator
- Converter
- 3:1 Booster
- 1" dia. extender probe
- Converter cable
- Power cable
- Wrench set

**static processing volume is aided by the addition of a mechanical mixer or stir bar.*

Flocell - Inline Processor

Flocells offer inline or continuous processing of large sample volumes. Flocells are ideal for mixing, dispersing and cell lysis applications. The 4583 model is powered by the Q1375 watt Sonicator and is capable of processing 20 liters per minute (degree of processing needed and sample viscosity can affect flow rate).

The unprocessed sample is introduced through the bottom inlet and passes across a specially designed ultrasonic inline probe. The degree of processing can be controlled by adjusting the intensity of sonication as well as flow rate.

Batch volumes can be recirculated through the system multiple times if increased sonication time is needed. Multiple units can be used in succession to reduce processing time and/or maintain a higher flow rate. The Flocell has a water jacket for coolant if needed.



PART NO. Q1375F INCLUDES:

- Q1375 Sonicator
- 4583 Flocell (see page 11 for details)

QA40 Atomizer



The QA40 Atomizer uses ultrasonic energy to generate a low-velocity, gentle spray. The sample can be precisely delivered to the target area. Overspray is virtually eliminated resulting in material savings. The atomizer can run continuously or be programmed to pulse on and off.

With water, the average droplet size is 50 microns. The minimum sample volume that can be effectively atomized is 2 $\mu\text{l}/\text{sec}$. To optimize atomization, the liquid product's solid concentration must be below 30% and viscosity below 50 cps. A low pressure metering pump is recommended to deliver the liquid sample to the nozzle. Gravity feed can also be utilized.

FEATURES:

- 50 micron droplet size
- Programmable operation
- Multiple probe options

PART NO. QA40 INCLUDES:

- Generator
- Converter
- Standard probe
- Power cable
- Converter cable
- Wrench set

TECHNICAL SPECIFICATIONS:

Frequency:	40 kHz
Programmable Timer:	10 hours
Adjustable Pulse On/Off:	1 second to 1 minute
Dimensions:	8" W x 13.75" L x 5.75" H
Voltage:	110V, 50/60 Hz

Specify desired voltage for export.

www.sonicator.com

53 Church Hill Road
Newtown, CT 06470
phone 877.338.9636
fax 203.426.7026
email info@sonicator.com

QSONICA *manufacturers of*
MISONIX SONICATORS